

DEPARTMENT OF THE ARMY TECHNICAL MANUAL

---

OPERATOR'S MANUAL  
TRUCK, LIFT, FORK, ELECTRIC  
SOLID RUBBER TIRES  
2000 POUND CAPACITY  
ARMY MODEL MHE-197  
BAKER MODEL FTD-020-EE  
FSN 3930-724-4058, 100 IN. LIFT  
FSN 3930-965-0075, 130 IN. LIFT

---

This copy is a reprint which includes current pages from Change 2.

HEADQUARTERS, DEPARTMENT OF THE ARMY  
FEBRUARY 1965

## **SAFETY PRECAUTIONS**

### **Before Operation**

When servicing battery, do not smoke or use flame in the vicinity. Batteries generate hydrogen, a highly explosive gas.

Avoid contact with the battery electrolyte. If the solution comes in contact with the skin, rinse the area immediately with clean water to avoid skin burns.

Check equipment logbook for record of proper servicing and maintenance.

Check the operating area to be sure it is clear of personnel and obstructions.

### **During Operation**

Be alert for other workers to be sure they are not in the way of the load or the moving truck.

Be sure there is sufficient clearance overhead and on each side of the truck.

Always travel with the mast tilted back and with forks raised just high enough to clear any uneven floor conditions.

Avoid sudden starting and stopping of the truck. Reduce speed when making a turn.

Face in the direction of travel.

Know the rated capacity of the truck and do not overload it. Never pick up a load until certain it can be carried safely.

Make sure the load is steady before lifting it and keep the load against the carriage backrest.

When transporting bulky loads, travel in reverse. Always descend ramps in reverse when carrying a load.

When unloading a heavy elevated load, position the load directly over the unloading spot, as low as possible, before tilting the mast forward.

Be very careful when high-tiering.

Do not butt loads with the forks or with the rear of the truck.

Report any evidence of faulty truck performance.

### **After Operation**

Make sure forks are lowered to the ground and handbrake is engaged firmly.

If truck is parked on an incline, block at least two wheels in the event of handbrake failure.

Change in force: C 2

CHANGE }  
No. 2 }

HEADQUARTERS  
DEPARTMENT OF THE ARMY  
WASHINGTON, D.C., 17 May 1972

**Operator's Manual**

**TRUCK, LIFT, FORK; SOLID RUBBER TIRES; 2,000-  
POUND CAPACITY; (ARMY MODEL MHE 197, BAKER  
MODEL FTD-020-EE) FSN 3930-724-4058, 100-INCH  
LIFT; FSN 3930-965-0075, 130-INCH LIFT**

TM 10-3930-253-10, 15 February 1965, is changed as follows:

Page 3. Paragraph 4 is superseded.

**4. Reporting of Equipment Publication.**

The reporting of errors, omissions, and recommendations for improving, this publication by the individual user should be submitted on DA Form 2028 (recommended Changes to Publications) and forwarded direct to Commanding General, U.S. Army Mobility Equipment Command, ATTN: AMSME-MPP 4300 Goodfellow Boulevard, St. Louis, Mo. 63120.

Page 19. Appendix II is superseded.

**APPENDIX II  
BASIC ISSUE ITEMS LIST AND ITEMS  
TROOP INSTALLED OR AUTHORIZED**

**Section I. INTRODUCTION**

**B-1. Scope**

This appendix lists items required by the operator for operation of the truck.

a. *Source, Maintenance, and Recoverability Code(s) (SMR):*

(1) *Source code*, indicates the source for the listed item. Source codes are:

**B-2. General**

This list is divided into the following sections:

a. *Basic Issue Items List-Section II.* Not applicable.

b. *Items Troop Installed or Authorized List - Section III.* A list of items in alphabetical sequence, which at the discretion of the unit commander may accompany the truck. These items are NOT SUBJECT TO TURN-IN with the truck when evacuated.

*Code*

*Explanation*

P Repair parts, special tools and test equipment supplied from GSA/DSA or Army supply system and authorized for use at indicated maintenance levels.

P2 Repair parts, special tools and test equipment which are procured and stocked for insurance purposes because the combat or military essentiality of the end item dictates that a minimum quantity be available in the supply system.

**B-3. Explanation of Columns.**

The following provides an explanation of columns in the tabular list of Basic Issue Items List, Section II and Items Troop Installed or Authorized, Section III.

(2) *Maintenance code*, indicates the lowest

\* This change supersedes C1, 1 September 1966.

level of maintenance authorized to install the listed item. The maintenance level code is:

*Code Explanation*  
**C** Crew/Operator  
 (3) *Recoverability code*, indicates whether unserviceable items should be returned for recovery or salvage. Items not coded are nonrecoverable. Recoverability codes are:

*Code Explanation*  
**R** Applied to repair parts (assemblies and components), special tools and test equipment which are considered economically repairable at direct and general support maintenance levels.  
**S** Repair parts, special tools, test equipment and assemblies which are economically repairable at DSU and GSU activities and which normally are furnished by supply on an exchange basis.

*b. Federal Stock Number.* This column indicates the Federal stock number assigned to the item and will be used for requisitioning purposes.

*c. Description.* This column indicates the Federal item name and any additional description of the item required.

*d. Unit of Measure (U/AM).* A 2 character alphabetic abbreviation indicating the amount or quantity of the item upon which the allowances are based, e.g., ft, ea, pr, etc.

*e. Quantity Furnished with Equipment (BILL).* (Not applicable).

*f. Quantity Authorized (Items Troop Installed or authorized).* This column indicates the quantity of the item authorized to be used with the equipment.

**Section III. ITEMS TROOP INSTALLED OR AUTHORIZED LIST**

<b>(1) SMR Code</b>	<b>(2) Federal stock number</b>	<b>(3) Description  Ref No. &amp; Code Usable on Code</b>	<b>(4) Unit of Meas</b>	<b>(5) Qty Auth</b>
	7510-889-3494	BINDER, Looseleaf	EA	1
	7520-559-9618	CASE, maintenance and operation manuals	EA	1
	4210-889-2222	EXTINGUISHER, Fire	EA	1

By Order of the Secretary of the Army:

Official:  
 VERNE L. BOWERS,  
 Major General, United States Army,  
 The Adjutant General.

W. C. WESTMORELAND,  
 General, United States Army,  
 Chief of Staff.

Distribution:

To be distributed in accordance with DA Form 12-25A (qty rqr block No. 893) Operator Maintenance Requirements for Warehouse Equipment.

TECHNICAL MANUAL }  
 No. 10-3930-255-10 }

HEADQUARTERS  
 DEPARTMENT OF THE ARMY  
 WASHINGTON, D.C., 15 February 1965

**Operator's Manual**

**TRUCK LIFT, FORK, ELECTRIC  
 SOLID RUBBER TIRES  
 2000 POUND CAPACITY  
 ARMY MODEL MHE-197  
 BAKER MODEL FTD-020-EE  
 (FSN 3930-724-4058) 100 IN. LIFT  
 (FSN 3930-965-0075) 130 IN. LIFT**

		Paragraph	Page
CHAPTER	1. INTRODUCTION		
Section	I. General		
	Scope -----	1	3
	Appendixes -----	2	3
	Forms, records, and reports-----	3	3
	Recommended changes -----	4	3
	Orientation-----	5	3
	II. Description and Data		
	Description -----	6	3
	Tabulated data -----	7	4
	Difference in models-----	8	6
CHAPTER	2. OPERATING INSTRUCTIONS		
Section	I. Service Upon Receipt of Truck		
	General-----	9	7
	Responsibilities-----	10	7
	II. Controls and Instruments		
	General-----	11	7
	Controls -----	12	7
	Instruments-----	13	9
	III. Operation Under Usual Conditions		
	General-----	14	9
	Driving the truck-----	15	9
	Picking up the load -----	16	9
	Depositing the load-----	17	10
	Stopping the truck -----	18	10
	IV. Operation of Equipment Used in Conjunction With the Truck		
	General-----	19	11
	Operating the extinguisher -----	20	11
CHAPTER	3. MAINTENANCE INSTRUCTIONS		
Section	I. Special Tools and Equipment		
	Special tools -----	21	12
	Equipment -----	22	12

		Paragraph	Page
	II. Lubrication		
	General-----	23	12
	Operator responsibilities -----	24	12
	III. Preventive Maintenance Services Under Usual Conditions		
	General-----	25	12
	Daily preventive maintenance services-----	26	12
	IV. Preventive Maintenance Services Under Unusual Conditions		
	General-----	27	15
	Operation in extreme heat-----	28	15
	Operation in extreme cold-----	29	15
	Operation in sandy terrain-----	30	15
	Operation in tropical areas -----	31	15
	V. Troubleshooting		
	Definition-----	32	15
	Operator responsibilities -----	33	15
CHAPTER	4. DEMOLITION OF TRUCK		
	General-----	34	16
	Demolition to render the forklift truck inoperative -----	35	16
	Demolition by explosives or weapons fire -----	36	16
	Other demolition methods -----	37	16
	Training-----	38	16
APPENDIX	I. REFERENCES -----		17
	II. BASIC ISSUE ITEMS LIST AND MAINTENANCE AND OPERATING SUPPLIES-----		19

# CHAPTER 1 INTRODUCTION

---

## Section I. GENERAL

### 1. Scope

a. This manual is for the use of personnel responsible for the operation and operator maintenance of the Truck, Lift, Fork, Electric, Solid Rubber Tires, 2,000 Pound Capacity, Baker Model FTD-020-EE, Army Model MHE-197, Federal Stock Number 3930-724-4058 for 100 in. lift and Federal Stock Number 3930-965-0075 for 130 in. lift, procured under Contract Number DSA-4-020840-MP302.

b. It provides the operator with the necessary instructions to operate the truck and to perform his required maintenance services. These maintenance services have been assigned to the operator within the limits of the daily preventive maintenance services (para. 26).

### 2. Appendixes

Appendix I contains a list of publications applicable to this manual. Appendix II contains the list of basic issue items and maintenance and operating supplies authorized the operator of this equipment. The maintenance allocation chart is listed in TM 10-3930-255-20.

### 3. Forms, Records, and Reports

The forms, records, and reports applicable to the operation and operator maintenance of this truck are listed and described in TM-38-750.

### 4. Recommended Changes

The direct reporting by the individual user of errors, omissions and recommendations for improving this manual is authorized and encouraged. DA Form 2028 (Recommended Changes to DA Publications) will be used for reporting these improvements. This form will be completed in triplicate using pencil, pen or typewriter and will be forwarded direct to Commanding General, U.S. Army Mobility Equipment Center, ATTN: SMOME-MMP, P.O. Drawer 58, St. Louis, Mo. 63166.

### 5. Orientation

Throughout this manual, the use of the terms *right*, *left*, *front*, and *rear*, indicates directions from the viewpoint of the operator sitting in the seat of the truck.

## Section II. DESCRIPTION AND DATA

### 6. Description

Army Model MHE-197 (Baker Model-020-EE, type EE, spark enclosed) is a nontactical forklift truck designed for warehouse operation. This truck (figs. 1 and 2) can be used to load, transport, unload, and stack loads weighing as much as 2,000 pounds at a load center of 24

inches. (The load center is measured from the heel of the forks.) The Model FTD-020-EE truck, Federal stock number 3930-724-4058, is designed to lift loads to a height of 100 inches. The Model FTD-020-EE truck, Federal stock number 3930-965-0075, is designed to lift loads to a height of 130 inches.

AGO 7555A

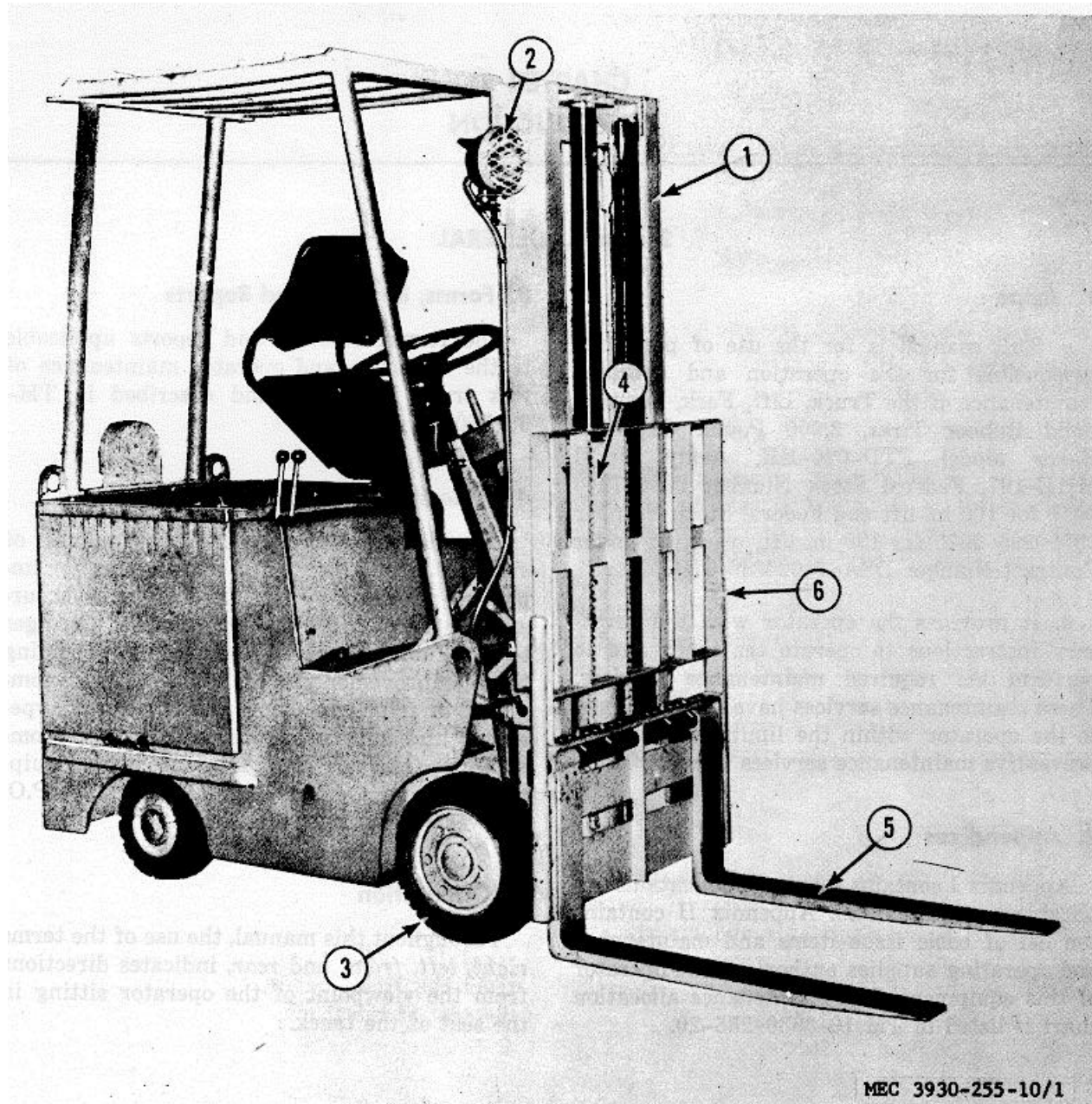

MEC 3930-255-10/1

1 Mast  
2 Headlight

3 Wheel, drive  
4 Cylinder, lift

5 Forks, load  
6 Backrest, load

Figure 1. Truck, three-quarter front view.

**7. Tabulated Data**

*a. Capacities.*

Differential-----2 pt  
Gearbox-----1 ½ pt  
Hydraulic system -----4 ½ gal

*b. Dimensions and Weight (FSN 3930-724-4058).*

Ground clearance (at mast center)-----3 in.  
Height (overall):  
With uprights extended  
    (less back rest)-----120 in.  
With uprights retracted -----68 in.

AGO 7555A



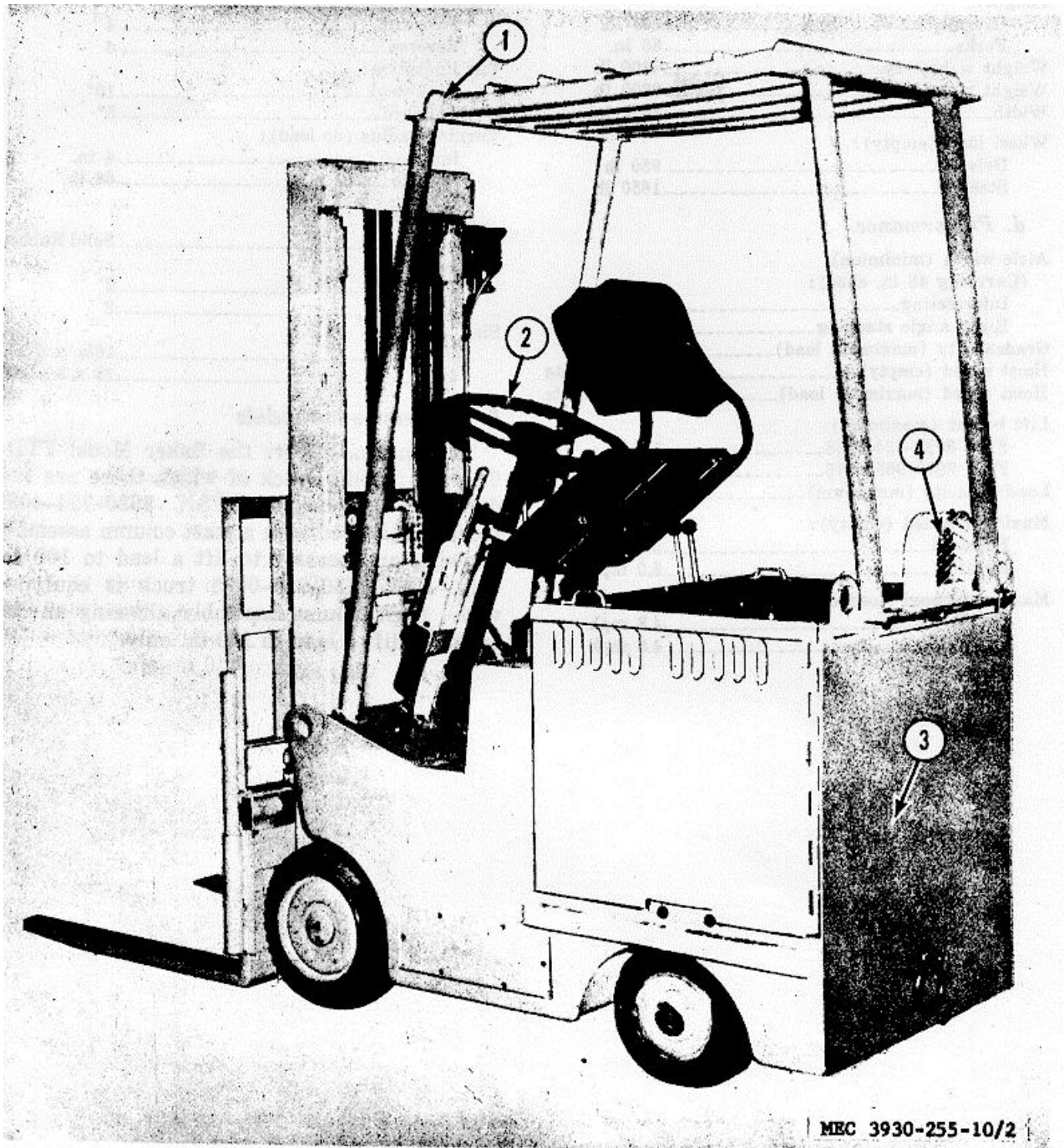

MBC 3930-255-10/2

1 Guard, overhead

2 Wheel, steering

3 Counter weight

4 Stoplight-taillight

Figure 2. Truck, three-quarter rear view.

Length:

Overall-----106 in.  
 Forks-----36 in.  
 Weight w/battery-----5200 lb  
 Weight w/o battery-----3600 lb  
 Width-----34 ¾ in.

Wheel load (empty):

Drive-----950 lb  
 Steer-----1650 lb

AGO 7555A

c. Dimensions and Weight (FSN 39310-965-

0075).

Ground clearance (at mast center)-----3 in.

Height (overall):

With uprights extended  
 (less back rest)-----147 in.  
 With uprights retracted-----89 in.

Length:  
 Overall----- 106 in.  
 Forks ----- 36 in.  
 Weight w/battery-----5200 lb  
 Weight w/o battery -----3600 lb  
 Width 34 ¾ in.  
 Wheel load (empty):  
 Drive -----950 lb  
 Steer -----1650 lb

*d. Performance.*

Aisle width (minimum)  
 (Carrying 48 in. cube):  
 Intersecting -----70 in.  
 Right angle stacking -----128 in.  
 Gradeability (maximum load) -----15%  
 Hoist speed (empty) -----50 ft/minute  
 Hoist speed (maximum load) -----35 ft/minute  
 Lift height (maximum):  
 FSN 3930-724-4058----- 100 in.  
 FSN 3930965-0075----- 130 in.  
 Load capacity (maximum) -----2,000 lb  
 Maximum speed (empty):  
 Forward -----5.0 mph  
 Reverse -----5.0 mph  
 Maximum speed (loaded):  
 Forward -----4.8 mph  
 Reverse -----4.8 mph

Number of speed steps:  
 Forward-----4  
 Reverse-----4  
 Tilt limitation:  
 Backward -----10°  
 Forward -----5°  
 Turning radius (no load):  
 Inside-----4 in.  
 Outside -----68 in.

*e. Tires.*

Type ----- Solid  
 Rubber  
 Number:  
 Drive-----2  
 Steer -----2  
 Size:  
 Drive-----16 ¼ x 5 x 8  
 Steer-----13 x 3 ½ x 8

**8. Difference in Models**

This manual covers the Baker Model FTD-020-EE forklift truck of which there are two different lift heights. FSN 3930-724-4058 truck is equipped with a mast column assembly allowing an operator to lift a load to 100 in. only. FSN 3930-965-0075 truck is equipped with mast column assembly allowing an operator to lift a load to 180 in. only.

**AGO 7555A**

## CHAPTER 2 OPERATING INSTRUCTIONS

---

### Section I. SERVICE UPON RECEIPT OF TRUCK

#### 9. General

When a new or used truck is received by an organization, it must be serviced to prepare it for operation.

#### 10. Responsibilities

The services performed upon receipt of the

truck are the responsibility of the using organization and will be performed by organizational maintenance personnel. When battery requirements are determined, refer to TM 10-3930-255-35 for installation of battery positioning parts. The operator will assist in these services when directed to do so by the commanding officer.

### Section II. CONTROLS AND INSTRUMENTS

#### 11. General

This section furnishes the operator with illustrations and sufficient information concerning the location and the use of the various controls and instruments to properly operate the truck.

#### 12. Controls

a. *Operator's Seat.* As the operator places his weight on the operator's seat (1, fig. 3), a switch is closed which activates the travel motor circuit. Simultaneously, the travel motor brake is released. As the driver removes his weight from the seat, the motor brake is engaged and the travel motor circuit is opened.

b. *Horn Button.* The horn button (4) is located in the center of the steering handwheel. Depress the button to sound horn.

c. *Parking Brake Lever.* The parking brake lever (5) is located to the left of the operator's seat in front of the cowl. Pull up on the lever to apply the brake and hold the truck in a stationary position. Move the lever downward to release brake.

d. *Steering Handwheel.* The steering handwheel (3) controls the direction of travel of the truck. Turn the handwheel to the right (clockwise) to move the truck to the right; turn the handwheel to the left (counterclockwise) to move the truck to the left.

e. *Accelerator Pedal.* The accelerator pedal (10) is located on the floor plate, convenient to the operator's right foot. Depression of the accelerator pedal either rapidly or slowly will cause the truck to move in the direction selected at the speed and acceleration desired by the operator. Release the pressure on the pedal to slow the speed of the truck.

f. *Light Switch.* The light switch (6) is located on the lower right side of the instrument case. Push the light switch up to turn on the headlight and taillight. Push the light switch down to turn off the headlight and taillight.

g. *Lift Control Lever.* The lift control lever (13) is located on the cowl to the right of the operator's seat. Move the lever to the rear to lift the forks. Move the lever forward to lower the forks.

h. *Tilt Control Lever.* The tilt control lever (12) is located directly to the right of the lift control lever. Move the tilt control lever forward to tilt the forks forward. Move the lever backward to tilt the forks backward.

i. *Direction Control Lever.* The direction

AGO 7555A

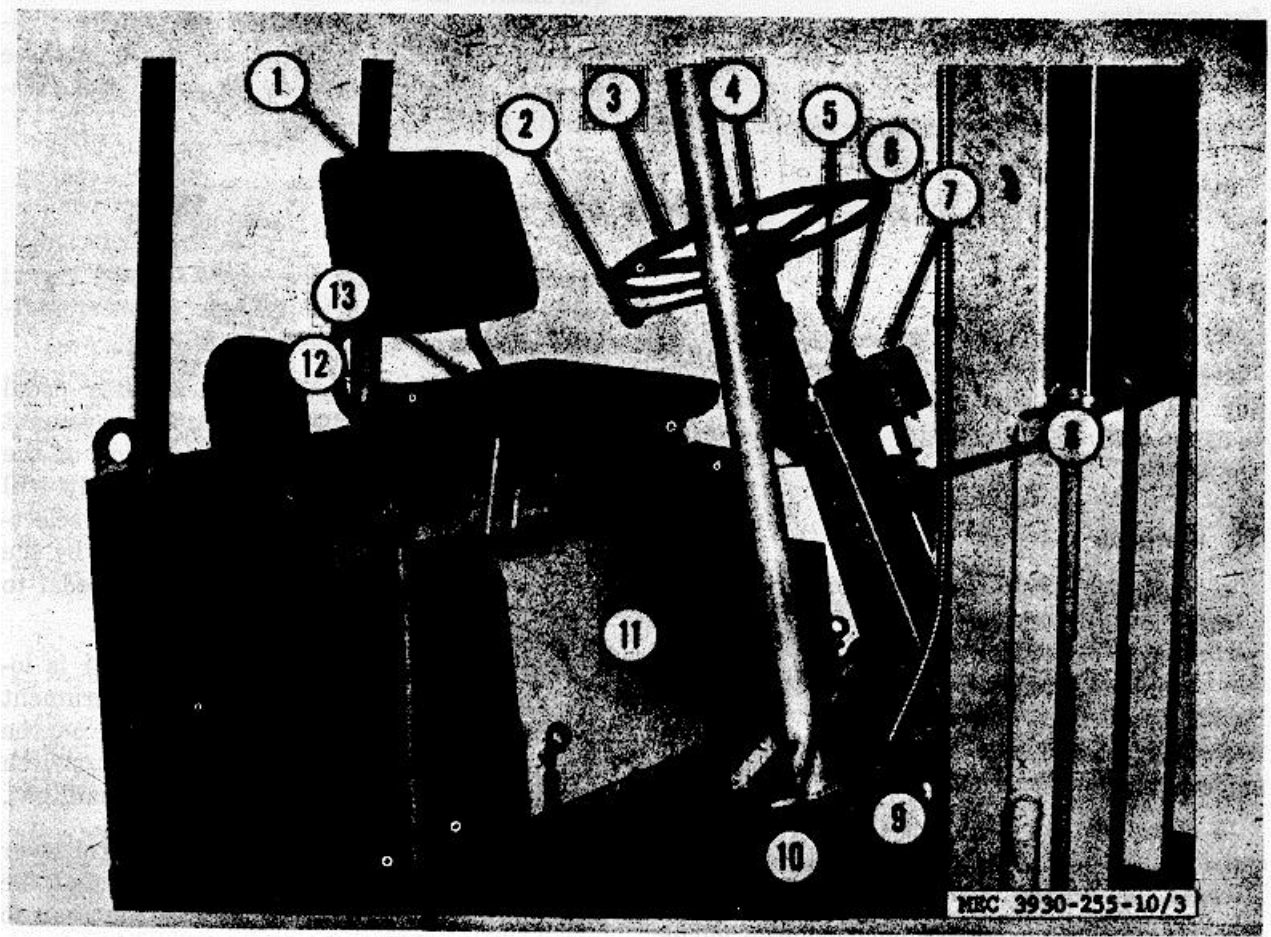

- 1 Operator's seat
- 2 Direction control lever
- 3 Steering handwheel
- 4 Horn button
- 5 Parking brake lever

- 6 Light switch
- 7 Hourmeter
- 8 Fire extinguisher
- 9 Brake pedal

- 10 Accelerator pedal
- 11 Seat adjuster
- 12 Tilt control lever
- 13 Lift control lever

*Figure 3. Controls and instruments.*

AGO 7555A

control lever (2) is located on the right side of the steering column. This lever provides three position control of the truck, forward, off, and reverse. Move the lever forward for forward travel, move the lever to the center position for off, and move the lever backward for reverse travel. Leave the lever in the off position when the truck is parked. The directional control lever may be used for either forward or reverse torque braking. Move the direction control lever in the opposite position you are traveling. The truck will come to almost a complete stop before going in the opposite direction. Depress the accelerator pedal if more severe torque braking is required.

*j. Brake Pedal.* The brake pedal (9) is located on the floor immediately to the right of the steering column. Depress the brake pedal to

stop the truck and simultaneously illuminate the stoplight.

*k. Seat Adjuster.* The seat adjuster (11) is located on the lower left side of the operator's seat. Move the adjuster lever toward the seat and move the seat forward or backward as desired. Release the adjuster lever when seat is in position.

### **13. Instruments**

The hourmeter (7) is the only instrument used on this truck. It is located on the uppermost part of the instrument case. This meter operates only when the truck is in motion. The figure (extreme right center) records 10ths of an hour. The small indicator (upper right) visibly turns when the meter is recording.

## **Section III. OPERATION UNDER USUAL CONDITIONS**

### **14. General**

A person selected to operate this forklift truck must be an experienced operator of materials handling equipment or heavy-duty equipment. In addition, each operator must undergo a thorough training program to acquaint him with the specific operating characteristics of this truck.

### **15. Driving the Truck**

*a.* Perform the daily preventive maintenance services required by paragraph 26.

*b.* Before boarding truck, put the direction control lever (para. 12i) in the center-off position.

*c.* Mount truck and take position in operator's seat (para. 12a).

*d.* Depress brake pedal (para. 12j) with right foot, and simultaneously release parking brake lever (para. 12c) with left hand.

*e.* Move the lift control level (para. 12g) gradually to the rear to raise the forks to normal traveling position (8 to 10 inches above working surface).

*f.* Move the tilt control level (para. 12h) backward and tilt the forks backward.

*g.* Move the direction control lever (para. 12i) from the center-off position to forward or reverse position, depending on desired direction.

*h.* Place foot on the accelerator pedal and gradually depress the accelerator pedal until truck begins to travel. Continue to depress the accelerator pedal until safe operating speed is attained. If the truck fails to move, report this to the proper authority.

### **16. Picking Up the Load**

*a.* Approach the load squarely and halt the truck. Move the tilt control lever (para. 12h) forward and bring the mast assembly to the vertical position. Raise or lower the forks to the proper height to pick up the load.

*b.* Move the truck forward until the forks are positioned under the load. Make certain the forks are fully inserted in the pallet or under the load.

*c.* Apply the parking brake to prevent the truck from shifting position during the lifting operation.

*d.* Move the direction control lever (para. 12i) to the center-off position.

*e.* Move the lift control level (para. 12g) to the rear and raise the load approximately

**AGO 7555A**

12 inches above ground level. Release the lift control lever. Move the tilt control lever backward to tilt the forks backward. Release the tilt control lever.

f. Move the direction control lever (para. 12*i*) from the center-off position to the proper position for the desired direction of travel.

g. Release the parking brake lever, depress the accelerator pedal, and move the load to the desired location.

## 17. Depositing the Load

### a. *Depositing the Load on a Tiered Stack.*

- (1) Move the lift control lever to the rear until the load reaches the desired height above the tier.
- (2) Drive the truck forward until the load is above its resting place.
- (3) Pull up on the parking brake lever to apply the parking brake.
- (4) Move the direction control lever to the center-off position. Move the tilt control lever forward and tilt the forks forward until the load is aligned with the tier.
- (5) Move the lift control lever forward and carefully lower the load into position on the tier. Continue to lower the forks until they can be easily withdrawn from the pallet.
- (6) Move the direction control lever to the reverse position. Release the parking brake lever, and slowly back the truck away from the tiered stack until the forks are clear.
- (7) Move the lift control lever forward to lower the forks into normal traveling position (8 to 10 inches above surface).

### b. *Depositing the Load in a Storage Area.*

- (1) Carefully drive up to the position at

which the load is to be deposited. Depress the brake pedal to halt the truck.

- (2) Apply the parking brake, and move the direction control lever to the center-off position.
- (3) Move the tilt control lever forward and bring the mast assembly to the vertical position.
- (4) Move the lift control lever forward and carefully lower the load to the ground. Continue to lower the forks until they can be easily withdrawn from under the load.
- (5) Place the direction control lever in the reverse position. Release the parking brake lever, and slowly back the truck away from the deposited load.

## 18. Stopping the Truck

a. Remove foot from the accelerator pedal.

b. Apply gradual pressure on the brake pedal to bring the truck to a safe smooth stop. Avoid sudden stops.

c. Apply the parking brake. Move the direction control lever to the center-off position.

d. Move the tilt control lever forward to bring the mast to the vertical position.

e. Move the lift control lever forward and lower the forks to the ground.

f. As the operator removes his weight from the seat, the travel motor brake is applied and the seat switch is opened, thereby cutting off current to the travel motor.

g. Every 8 hours or after a day's work with the truck, the operator must have the battery charged over night for efficient operation of the forklift truck the following day.

**AGO 7555A**

**Section IV. OPERATION OF EQUIPMENT USED  
IN CONJUNCTION WITH THE TRUCK**

**19. General**

This section contains instructions for operating the portable fire extinguisher (8, fig. 3) that is supplied with the truck.

**20. Operating the Extinguisher**

a. Disconnect the clamp that secures the extinguisher to its mounting bracket, swing the clamp open, and remove the extinguisher.

b. Hold the extinguisher upright and raise the large locking handle (2) to break the seal.

c. Aim the nozzle at the base of the fire and depress the small operating lever with the thumb.

d. Direct the discharge at the base of the fire with a side-to-side sweeping motion.

**AGO 7555A**

**CHAPTER 3  
MAINTENANCE INSTRUCTIONS**

---

**Section I. SPECIAL TOOLS AND EQUIPMENT**

**21. Special Tools**

There are no special tools necessary for the operation or operator maintenance of this truck.

**22. Equipment**

The items of equipment supplied with this truck are listed in the basic issue items list (app. II).

**Section II. LUBRICATION**

**23. General**

The lubrication of this truck is the responsibility of the using organization and will be performed by organizational personnel.

**24. Operator Responsibilities**

The operator will be alert to detect signs of vehicle malfunctioning from lack of lubrication. He will report these conditions immediately to the proper authority.

**Section III. PREVENTIVE MAINTENANCE SERVICES  
UNDER USUAL CONDITIONS**

**25. General**

To insure that the truck is ready for operation at all times, it must be inspected systematically, so that defects may be discovered and corrected before they result in serious damage or failure. The necessary preventive maintenance services to be performed are listed and described in paragraphs 27-31. The item numbers indicate the sequence of minimum inspection requirements. Defects discovered during operation of the truck will be noted for future correction, to be made as soon as operation has ceased. Stop operation immediately if a deficiency is noted during operation

which would damage the equipment if operation were continued. All deficiencies and shortcomings will be recorded with the corrective action taken on DA Form 2404 (Equipment inspection and Maintenance worksheet) at the earliest possible opportunity.

**26. Daily Preventive Maintenance Services**

This paragraph contains an illustrated tabulated listing of preventive maintenance services which must be performed by the operator. Refer to figure 4 for the daily preventive maintenance services.

**AGO 7555A**



**PREVENTIVE MAINTENANCE SERVICES  
DAILY**

TM 10-3930-255-10

**BAKER MODEL FTD-020-EE  
ARMY MODEL MHE 197**

**FORK LIFT TRUCK**

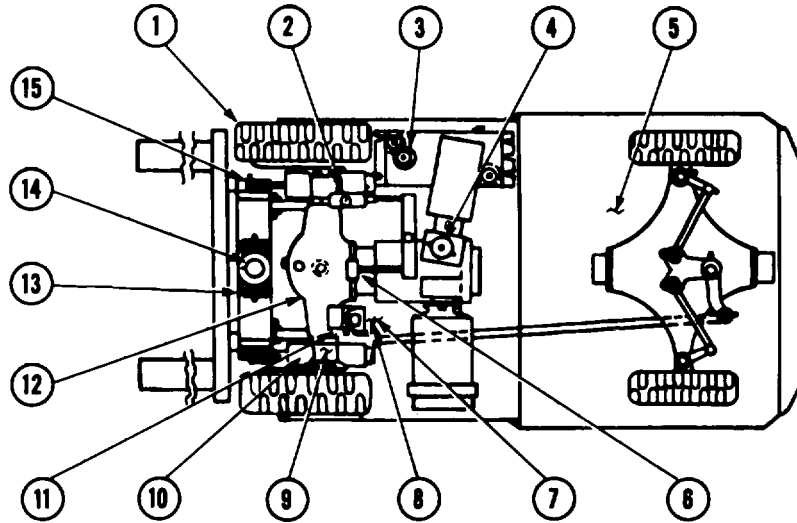

ITEM	LUBRICATE IN ACCORDANCE WITH CURRENT LUBRICATION ORDER	PAR REF
1	TIRES. Check for cuts. Remove embedded foreign material. (Weekly)	
2	BRAKE MASTER CYLINDER. Check for leaks.	
3	HYDRAULIC OIL TANK. Check oil level, fill as required. Reference L.O. (Weekly)	
4	POWER STEERING RESERVOIR. Check lines and reservoir for leaks.	
5	BATTERY. Check for cracks and leaks. Add fluid as needed.	
6	BRAKE PEDAL. Check for strong pressure when brake pedal is applied.	
7	HORN. Check operation.	
8	CONTROLS AND INSTRUMENT. Check controls for proper operation. Controls should operate freely without binding. Hourmeter indicates total hours of operation.	
9	FIRE EXTINGUISHER. Inspect for broken seal and correct charge.	

MEC 3930-255-10/4 (1)

*Figure 4. Daily preventive maintenance services.*

AGO 7555A

ITEM		PAR REF
10	TILT CYLINDERS. Check for leaks.	
11	HANDBRAKE. Check operation.	
12	DRIVE AXLE. Check for leaks. (Weekly)	
13	LIFT CHAIN. Check for cracked, broken or excessively worn links. (Weekly)	
14	LIFT CYLINDER. Check for leaks.	
15	LIGHTS. Check for defective lamp or lamp unit.	

MEC 3930-255-10/4 (2)

Figure 4. - Continued.

AGO 7555A

## **Section IV. PREVENTIVE MAINTENANCE SERVICES UNDER UNUSUAL CONDITIONS**

### **27. General**

When the truck is operated under unusual conditions, extra care must be taken to maintain the truck in good operating condition. Certain additional services must be performed, and some of the regular preventive maintenance services must be performed more often.

### **28. Operation in Extreme Heat**

Check the battery electrolyte level more often, maintaining the level 3/8 inch above the plates. Have the specific gravity of the electro lyte checked more often.

### **29. Operation in Extreme Cold**

a. Shelter. Store the truck in a heated building or in a shelter, if possible. If a shelter is not

available, park the truck with the front end facing into the wind and cover the truck with tarpaulin.

b. Electrical System. Have the specific gravity of the battery electrolyte checked more often.

### **30. Operation in Sandy Terrain**

a. Be sure to remove sand from axles, wheels, steering spindles, and brake assemblies.

b. Protect the lift and tilt mechanisms from sand. During sandstorms, cover exposed parts of the lift and tilt cylinder piston rods.

### **31. Operation in Tropical Areas**

In tropical areas, corrosive action will take place almost immediately where paint is chipped or scratched from the truck. Inspect the truck often for signs of defective paint, and report this condition to the proper authority.

## **Section V. TROUBLESHOOTING**

### **32. Definition**

Troubleshooting is the process of locating and correcting malfunctions that may occur under normal operating conditions, and it is the responsibility of the using organization.

### **33. Operator Responsibilities**

The operator will report to the proper authority any deficiencies noted before, during, or after operation. Report any strange noises or subnormal operation immediately and as accurately as possible.

**AGO 7555A**

## CHAPTER 4 DEMOLITION OF TRUCK

### 34. General

When capture or abandonment of the forklift truck to an enemy is imminent, the responsible unit commander must make the decision either to destroy the equipment or to render it inoperative. Based on this decision, orders are issued which cover the desired extent of destruction. Whatever method of demolition is employed, it is essential to destroy the same vital parts of all forklift trucks and all corresponding repair parts.

### 35. Demolition to Render the Forklift Truck Inoperative

*a. Demolition by Mechanical Means.* Use sledge hammers, crowbars, axes, picks, or any other heavy tools which may be available to destroy the following:

- (1) Contactors.
- (2) Battery.
- (3) Hydraulic motor, traveling motor, and steering motor.

**Note.** The above steps are minimum requirements for this method.

- (4) Steering column.
- (5) Pumps.

*b. Demolition by Misuse.* Pour sand in the oil reservoir and operate the forklift truck until failure occurs.

### 36. Demolition by Explosives or Weapons Fire

*a. Explosives.* Place as many of the following charges as the situation permits and detonate them simultaneously with detonating cord and a suitable detonator.

- (1) One 1/2-lb charge on lift cylinder.
- (2) One 1/2-lb charge inside of each drive wheel.
- (3) One 1/2-lb charge inside of each steering wheel.

**Note.** The above are minimum requirements for this method.

- (4) One 1/2-lb charge inside of control panel.
- (5) One 1/2-lb charge on hydraulic oil pump and motor.
- (6) One 1/2-lb charge on the differential.
- (7) Two 1/2-lb charges on traveling motor.
- (8) One 1/2-lb charge on power steering pump and motor.
- (9) Two 1/2-lb charges inside of battery compartment.

*b. Weapons Fire.* Fire on the forklift truck with the heaviest practical weapons available.

### 37. Other Demolition Methods.

*a. Burning.* Pack rags, clothing, or canvas, under, around, and inside the forklift truck. Saturate this packing with gasoline, oil, or diesel fuel and ignite.

*b. Submersion.* Totally submerge the forklift truck in a body of water to provide water damage and concealment. Salt water will damage metal parts more than fresh water.

### 38. Training

All operators should receive thorough training in the destruction of the forklift truck. Refer to FM 5-25. Simulated destruction, using all of the methods listed above, should be included in the operator training program. It must be emphasized in training, that demolition operations are usually necessitated by critical situations when time available for carrying out destruction is limited. For this reason, it is necessary that operators be thoroughly familiar with all methods of destruction of equipment, and be able to carry out demolition instructions without reference to this or any other manual.

AGO 7555A

## APPENDIX I REFERENCES

---

1. **Dictionaries of Terms and Abbreviations**
  - AR 320-5 Dictionary of United States Army Terms
  - AR 320-50 Authorized Abbreviations and Brevity Codes
2. **Fire Protection**
  - SB 5-111 Supply of DA Approved Fire Extinguishers to Army Troop Users
  - TM 5-687 Repair and Utilities; Fire Protection Equipment and Appliances; Inspections, Operations, and Preventive Maintenance
3. **Lubrication**
  - LO 10-3930-255-20 Truck, Lift, Fork, Electric, Solid Rubber Tires, 2,000 Pounds Capacity; Army Model MHE-197, Baker Model FTD-020-EE, (FSN 3930-724-4058) 100 In. Lift (FSN 3930-965-0075) 130 In. Lift.
4. **Painting**
  - TM 9-213 Painting Instructions for Field Use
5. **Preventive Maintenance**
  - AR 750-5 Organization, Policies, and Responsibilities for Maintenance Operation
  - TB ENG 347 Winterization Techniques for Engineer Equipment
  - TM 5-764 Electric Motor and Generator Repair
  - TM 9-207 Operation and Maintenance of Army Materiel in Extreme Cold Weather (0° to --65° F.)
  - TM 9-6140-200-15 Operation and Organizational, Field and Depot Maintenance; Storage Batteries, Lead-Acid Type
  - TM 38-750 Army Equipment Record Procedures
6. **Publication Indexes**
  - DA Pam 108-1 Index of Army Motion Pictures, Filmstrips, Slides, Tapes, and Phono-Recordings
  - DA Pam 310-1 Index of Administrative Publications
  - DA Pam 310-2 Index of Blank Forms
  - DA Pam 310-3 Index of Training Publication
  - DA Pam 310-4 Index of Technical Manuals, Technical Bulletins, Supply Manuals (Types 4, 6, 7, 8, and 9) Supply Bulletins, Lubrication Orders, and Modification Work Orders
  - DA Pam 310-5 Index of Graphic Training Aids and Devices
  - DA Pam 310-25 Index of Supply Manuals-Corps of Engineers
7. **Radio Interference Suppression**
  - TM 11-483 Radio Interference Suppression

AGO 7555A

**8. Shipment and Limited Storage**

AR 743-505 Limited Storage of Corps of Engineers Mechanical Equipment  
TM 9-200 General Packaging Instructions for Ordnance General Supplies  
TM 38-230 Preservation, Packaging, and Packing of Military Supplies and Equipment

**9. Supply Publications**

FSC C9100-1L Fuels, Lubricants, Oils, and Waxes  
TM 10-3930-255-20P Organizational Maintenance Repair Parts and Special Tool List. Truck, Lift, Fork, Electric, Solid Rubber Tires, 2,000 Pound Capacity; Army Model MHE-197, Baker Model FTD-020-EE.

**10. Training Aids**

AR 600-55 Motor Vehicle Driver Selection, Testing, and Licensing  
FM 5-25 Explosives and Demolitions  
FM 21-5 Military Training Management  
FM 21-6 Techniques of Military Instruction  
FM 2130 Military Symbols  
TM 21-300 Driver Selection and Training (Wheeled Vehicles)

**AGO 7555A**

**APPENDIX II  
BASIC ISSUE ITEMS LIST AND MAINTENANCE  
AND OPERATING SUPPLIES**

---

**Section I. INTRODUCTION**

**1. General**

Section II lists the accessories, tools, and publications required in operator maintenance and operation initially issued with, or authorized for the Army model MHE-197 forklift truck. Section III lists the maintenance and operating supplies required for initial operation.

**2. Explanation of Columns Contained in Section II**

a. *Source Codes.* The information provided in each column is as follows:

- (1) *Materiel.* This column lists the basic materiel code number of the supply service assigned responsibility for the part. Those spaces left blank denote supply responsibility of the preparing agency. General Engineer supply parts are identified in the description column. Other basic materiel code numbers are

5-Engineer Materiel

10-Quartermaster Materiel

- (2) *Source.* The selection status and source of supply for each part are indicated by one of the following code symbols:

- (a) P-applied to high-mortality repair parts which are stocked in or supplied from the supply service depot system, and authorized for use at indicated maintenance level.

- (b) P1-applied to repair parts which, are low-mortality parts, stocked in or supplied from supply service depots, and authorized for installation at indicated maintenance level.

- (c) M-applied to repair parts which AGO 7555A are not procured or stocked but are to be

manufactured at indicated maintenance level.

- (d) X2-applied to repair parts which are not stocked. The indicated maintenance level requiring such repair parts will attempt to obtain them through cannibalization; if not obtainable through cannibalization, such repair parts will be requisitioned with supporting justification through normal supply channels.

- (3) *Maintenance.* The lowest maintenance level authorized to use, stock, install, or manufacture the part is indicated by the following code symbols:

O-Organizational Maintenance

- (4) *Recoverability.* Repair parts and/or tool and equipment items that are recoverable are indicated by one of the following code symbols:

- (a) R-applied to repair parts and assemblies which are economically repairable at direct and general support activities and are normally furnished by supply on an exchange basis.

- (b) T-applied to high-dollar value recoverable repair parts which are subject to special handling and are issued on an exchange basis. Such repair parts are normally repaired or overhauled at depot maintenance facilities.

- (c) U-applied to repair parts specifically selected for salvage by reclamation units because of precious metal content, critical materials, high-dollar value reusable casing, castings, and the like.

**AGO 7555A**

**Note. When no code is shown in the recoverability column, the part is considered expendable.**

b. *Federal Stock Numbers.* When a Federal stock number is available for a part, it will be shown in this column, and used for requisitioning purposes.

c. *Description.*

- (1) The item name and a brief description of the part are shown.
- (2) A five-digit Federal supply code for manufacturers and/or other supply services is shown in parentheses followed by the manufacturer's part number. This number will be used for requisitioning purposes when no Federal stock number is indicated in the Federal stock number column. *Example: (08645) 86453.*
- (3) The letters "GE" shown in parentheses immediately following the description, indicates General Engineer supply responsibility for the part.

d. *Unit of Issue.* Where no abbreviation is shown in this column, the unit of issue is "each."

e. *Quantity Issued With Equipment.* This column lists the quantities of repair parts, accessories, tools, or publications that are initially issued with each item of equipment. Those indicated by an asterisk are to be requisitioned through normal supply channels as required.

f. *Illustrations.* This column is subdivided into two columns which provide the following information:

- (1) *Figure number.* Provides the identifying number of the illustration.
- (2) *Item number.* Provides the referenced number for the parts shown in the illustration.

### 3. Index to Federal Supply Code for Manufacturers

05415-Baker Industrial Truck Division of Otis Elevator Co., Cleveland, Ohio

### 4. Explanation of Columns Contained in Section III

a. *Item.* This column contains numerical sequenced item numbers, assigned to each component application, to facilitate reference.

b. *Component Application.* This column identifies the component application of each maintenance or operating supply item.

c. *Source of Supply.* This column lists the basic materiel code number of the supply service assigned responsibility of the preparing agency. Other basic materiel code numbers are-

9-Ordnance Materiel

10-Quartermaster Materiel

d. *Federal Stock Number.* When a Federal stock number is available, it will be shown in this column and used for requisitioning purposes.

e. *Description.* The item and a brief description are shown.

f. *Quantity Required for Initial Operation.* This column lists the quantity of each maintenance or operating supply item required for initial operation of the equipment.

g. *Quantity Required for 8 Hours Operation.* Quantities listed represent the estimated requirements for an average 8 hours of operation.

h. **Notes.** This column contains informative notes keyed to data appearing in the preceding column.

AGO 7555A



**Section II. BASIC ISSUE ITEM LIST**

Mat	Source code			Federal stock No.	Description	Ut of Iss	Qty auth	Qty iss w/ equip	Illus	
	So	Maint	Rec						Fig. No	Item No.
10	P1	O	-----	7520-559-9618	Case, maintenance and operational manuals -----	ea	1	1		
5	X2	O	-----	4210-893-1092	Extinguisher, fire -----	ea	1	1		
10	X2	O	-----	-----	Fork Assembly (05415)700CJ2	ea	2	2		
10	X2	O	-----	-----	Fork Retainer (05415)509MAL1	ea	2	2		
10	X2	O	-----	-----	Headlight Assembly (05415)424MBP2	ea	1	1		
10	X2	O	-----	-----	Knob, directional control (81487)9203W7	ea	1	1		
10	X2	O	-----	-----	Battery Angles (05415)180MBA1	ea	2	2		
10	X2	O	-----	-----	Bar (05415)299NEG1	ea	1	1		
10	X2	O	-----	-----	Rollers (05415)465MCG1	ea	12	12		
10	X2	O	-----	-----	Angles (05415)288Y7255	ea	2	2		
10	X2	O	-----	-----	Flat Washer (96906)MS27183-15	ea	4	4		
10	X2	O	-----	-----	Lock Washer (96906)MS35338-27	ea	4	4		
10	X2	O	-----	-----	Screw cap, hexagon head, 3/4 in. 16 by 1 3/4 in. (96906) MS35291-65	ea	4	4		
10	X2	O	-----	-----	Screw cap, hexagon head, 3/4 in. 16 by 3/4 in. (96906)MS35291-58	ea	4	4		
					PUBLICATIONS					
					TM 10-3930-257-10					
					REPAIR PARTS					
					None authorized for operator maintenance.					
					SPECIAL TOOLS					
					None authorized for operator maintenance.					
					RECORDS					
10				7510-889-3494	EQUIPMENT LOG BOOK Consisting of the following DA Forms: 2408, 2408-1, 2408-2, 2408-3, 2408-5, 2408-6, 2408-7, 2408-8, 2408-10, and 2408-11.					

**Section III. MAINTENANCE AND OPERATING SUPPLIES**

Item	Component application	Source of supply	Federal stock No.	Description	Quantity required for initial operation	Quantity required for 8 hours operation	Notes
1	90 MAINTENANCE AND OPERATING SUPPLIES DIFFERENTIAL	-----	-----	LUBRICATING OIL, GEAR: 5 gal pail as follows: GO 90 ..... GOS.....	5 1/2 qt.	(1) 5 1/2 qt.	(1) See current LO for grade application and replenishment intervals. (2) Use oil as prescribed in item 3. (1)
		10	9150-577-5844				
		10	9150-257-5440				

**AGO 7555A**

Item	Component application	Source of supply	Federal stock No.	Description	Quantity required for initial operation	Quantity required for 8 hours operation	Notes
2	BRAKE MASTER CYLINDER	-----	-----	HYDRAULIC FLUID AUTOMOTIVE: 1 qt can.			
		10	9150-190-0933	HB -----	(1)	(1)	
3	POWER STEERING RESERVOIR.	-----	-----	LUBRICATING OIL, ENGINE:			
		10	9150-265-9425	OE 10 1 qt can	1 qt	(1)	
		10	9150-231-9037	9110 5 gal pail	1 qt	(1)	
		10	9150-242-7602	OES 1 qt can	1 qt	(1)	
4	HYDRAULIC OIL RESERVOIR.	-----	-----	LUBRICATING OIL, ENGINE:			
		10	9150-265-9428	OE 10 5 gal pail	30 qt	(1)	
		10	9150-242-7603	OES 5 gal pail	30 qt	(1)	
5	OIL CAN POINTS (2).	-----	-----	LUBRICATING OIL, ENGINE (2).	(1)		
6	LUBRICATION FITTINGS.	-----	-----	GREASE AUTOMOTIVE AND ARTILLERY.			
		10	9150-190-0904	GAA, 1 lb can	(1)		

By Order of the Secretary of the Army:

HAROLD K. JOHNSON,  
General, United States Army,  
Chief of Staff.

Official:

J. C. LAMBERT,  
Major General, United States Army,  
The Adjutant General.

Distribution:

Active Army:

USASA (1)	PG (2)
DCSLOG (1)	USAQMTTC (4)
CNGB (1)	QM Fld Maint Shops (2)
CAR (1)	Units org under fol TOE: (2 copies each)
CofEngrs (6)	3-117
CofSptS (1)	5-279
Dir of Trans (1)	5-500 (BB)
CC-E (1)	8-187
USCONARC (2)	9-197
USAMC (12)	9367
ARADCOM (2)	10-37
ARADCOM Rgn (2)	10-337
OS Maj Comd (3)	10-407
LOGCOMD (1)	10-417
USAMOCOM (2)	10-445
USAWECOM (5)	10-447
USAMICOM (5)	10-467
USAMUCOM (5)	10-500 (EE, EA, ED, EG)
USAECOM (5)	11-128
USASMC (1)	12-512
MDW (1)	2g-1
Armies (5)	29-53
Instl (2)	29-56
Svc Colleges (2)	29-57
Br Svc Sch (2) except	29-105
USAQMS (10)	29-107
USMA (1)	31-105
Army Dep. (4)	31-106
NLABS (4)	55-260
USA Mob Equip Cen (49)	55-457
Mbl Equip Man Fld Ofc (Ft Lee) (2)	55-458
POE (2)	55-500 (BE, JC)
USA Tml Comd (2)	57
Army Tml (2)	57-100
Arsenals (2)	29-105

NG: State AG (3).

USAR: None.

For explanation of abbreviations used, see AR 320-50.

\*U.S. GOVERNMENT PRINTING OFFICE: 1996-406-421/53140

AGO 7555A

RECOMMENDED CHANGES TO EQUIPMENT TECHNICAL PUBLICATIONS



THEN... JOT DOWN THE DOPE ABOUT IT ON THIS FORM, CAREFULLY TEAR IT OUT, FOLD IT AND DROP IT IN THE MAIL!

**SOMETHING WRONG WITH THIS PUBLICATION?**

FROM: (PRINT YOUR UNIT'S COMPLETE ADDRESS)

DATE SENT

PUBLICATION NUMBER

PUBLICATION DATE

PUBLICATION TITLE

BE EXACT... PIN-POINT WHERE IT IS

PAGE NO.

PARA-GRAPH

FIGURE NO.

TABLE NO.

IN THIS SPACE TELL WHAT IS WRONG AND WHAT SHOULD BE DONE ABOUT IT:

TEAR ALONG PERFORATED LINE

PRINTED NAME, GRADE OR TITLE, AND TELEPHONE NUMBER

SIGN HERE:

DA FORM 2028-2 JUL 79

PREVIOUS EDITIONS ARE OBSOLETE.

P.S.—IF YOUR OUTFIT WANTS TO KNOW ABOUT YOUR RECOMMENDATION MAKE A CARBON COPY OF THIS AND GIVE IT TO YOUR HEADQUARTERS.

